

CDL Marine Down Light

Product Introduction

Housing & Trim Rings

Galvanized Steel or SS316L housing, with RAL9016 white powder coated

Mounting

Recessed mounting, 150mm cut-out thickness of ceiling less than 30mm

Diffuser

Optional IP44 sealed diffuser on trim ring

Entries

Two M20 cable glands

Lamp Base

E27/G24q-2

Terminal Block

3 pole 6mm² max

Lamp

Compact fluorescent: 18W
Incandescent: 60W max

Ambient Temp

Standard: -25 °C~+45 °C

Dimmer

Optional dimming version

Application Area

IP20-44, Meeting room, entertaining room or other interior spaces

Certificate

DNV, B15



Ordering Information

CDL	-16	-IN60	-DIM	-S
	00-Galvanized Steel 16-316L	IN60-Incandescent Lamp 60W max CF18-CFL 18W	DIM-Dimmable	Blank-IP20 S-IP44 Diffuser

Commonly Ordered Luminaires

Lamp Source	Wattage	Volt/ Fre	Description	Material Code	Weight Kg
Compact Fluorescent	18W	220-240V 50/60Hz	CDL-00-CF18	CCL1204089	2
	18W Dimmable	220-240V 50/60Hz	CDL-00-CF18-DIM	CCL1204090	
Incandescent	60W max	220-240V 50/60Hz	CDL-00-IN60	CCL1204091	
	60W max with dimmer switch	220-240V 50/60Hz	CDL-00-IN60-DIM	CCL1204092	

Please consult Eaton's Crouse-Hinds for more configurations!

Dimensions

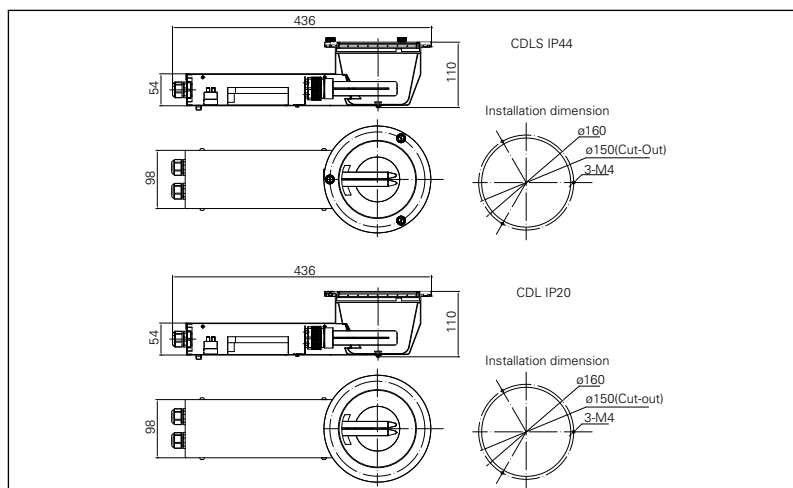

Polar Curves

